

General Description

The GreenMOS[®] MOSFET utilizes charge balance technology to achieve outstanding low on-resistance and lower gate charge. It is engineered to minimize conduction loss, provide superior switching performance and robust avalanche capability.

The GreenMOS[®] Generic series is optimized for extreme switching performance to minimize switching loss. It is tailored for high power density applications to meet the highest efficiency standards.

Features

- Low $R_{DS(ON)}$ & FOM
- Extremely low switching loss
- Excellent stability and uniformity

GreenMOS[®]



Applications

- Switch-Mode and Resonant-Mode Power Supplies
- DC-DC Converters
- PFC Circuits

Key Performance Parameters

Parameter	Value	Unit
V_{DS}	300	V
I_D , pulse	480	A
$R_{DS(ON)}$, max @ $V_{GS}=10V$	11	m Ω
Q_g	187	nC

Marking Information

Product Name	Package	Marking
OSG30R011H4ZF	TO247-4L	OSG30R011H4Z

Package & Pin Information

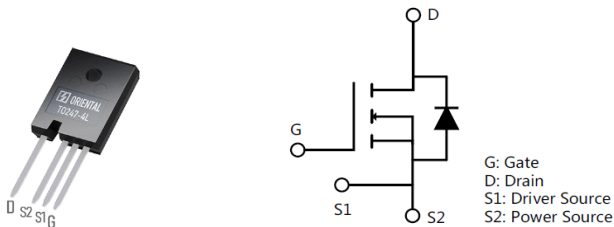

Absolute Maximum Ratings at $T_j=25^{\circ}\text{C}$ unless otherwise noted

Parameter	Symbol	Value	Unit
Drain-source voltage	V_{DS}	300	V
Gate-source voltage	V_{GS}	± 20	V
Continuous drain current ¹⁾ , $T_C=25^{\circ}\text{C}$	I_D	160	A
Continuous drain current ¹⁾ , $T_C=100^{\circ}\text{C}$		101	
Pulsed drain current ²⁾ , $T_C=25^{\circ}\text{C}$	$I_{D, pulse}$	480	A
Continuous diode forward current ¹⁾ , $T_C=25^{\circ}\text{C}$	I_S	160	A
Diode pulsed current ²⁾ , $T_C=25^{\circ}\text{C}$	$I_{S, pulse}$	480	A
Power dissipation ³⁾ , $T_C=25^{\circ}\text{C}$	P_D	694	W
Single pulsed avalanche energy ⁴⁾	E_{AS}	4000	mJ
Reverse diode dv/dt	dv/dt	20	V/ns
Operation and storage temperature	T_{stg}, T_j	-55 to 150	$^{\circ}\text{C}$

Thermal Characteristics

Parameter	Symbol	Value	Unit
Thermal resistance, junction-case	$R_{\theta JC}$	0.18	$^{\circ}\text{C}/\text{W}$
Thermal resistance, junction-ambient	$R_{\theta JA}$	62	$^{\circ}\text{C}/\text{W}$

Electrical Characteristics at $T_j=25^{\circ}\text{C}$ unless otherwise specified

Parameter	Symbol	Min.	Typ.	Max.	Unit	Test condition
Drain-source breakdown voltage	BV_{DSS}	300			V	$V_{GS}=0\text{ V}, I_D=2\text{ mA}$
Gate threshold voltage	$V_{GS(th)}$	3		5	V	$V_{DS}=V_{GS}, I_D=2\text{ mA}$
Drain-source on-state resistance	$R_{DS(ON)}$		4.6	11	m Ω	$V_{GS}=10\text{ V}, I_D=80\text{ A}$
			11.4			$V_{GS}=10\text{ V}, I_D=80\text{ A}, T_j=150^{\circ}\text{C}$
Transconductance	g_{fs}	80	130		S	$V_{DS}=10\text{ V}, I_D=80\text{ A}$
Gate-source leakage current	I_{GSS}			100	nA	$V_{GS}=20\text{ V}$
				-100		$V_{GS}=-20\text{ V}$
Drain-source leakage current	I_{DSS}			10	μA	$V_{DS}=300\text{ V}, V_{GS}=0\text{ V}$
Gate resistance	R_G		3.1		Ω	$f=1\text{ MHz}, \text{Open drain}$

Dynamic Characteristics

Parameter	Symbol	Min.	Typ.	Max.	Unit	Test condition
Input capacitance	C_{iss}		11005		pF	$V_{GS}=0\text{ V}$, $V_{DS}=50\text{ V}$, $f=100\text{ kHz}$
Output capacitance	C_{oss}		756		pF	
Reverse transfer capacitance	C_{rss}		36.8		pF	
Effective output capacitance, energy related	$C_{o(er)}$		682		pF	$V_{GS}=0\text{ V}$, $V_{DS}=0\text{ V}-240\text{ V}$
Effective output capacitance, time related	$C_{o(tr)}$		3107		pF	
Turn-on delay time	$t_{d(on)}$		36.8		ns	$V_{GS}=10\text{ V}$, $V_{DS}=150\text{ V}$, $R_G=2\ \Omega$, $I_D=80\text{ A}$
Rise time	t_r		15		ns	
Turn-off delay time	$t_{d(off)}$		132.4		ns	
Fall time	t_f		9.6		ns	

Gate Charge Characteristics

Parameter	Symbol	Min.	Typ.	Max.	Unit	Test condition
Total gate charge	Q_g		187		nC	$V_{GS}=10\text{ V}$, $V_{DS}=150\text{ V}$, $I_D=80\text{ A}$
Gate-source charge	Q_{gs}		63		nC	
Gate-drain charge	Q_{gd}		58		nC	
Gate plateau voltage	$V_{plateau}$		6.2		V	

Body Diode Characteristics

Parameter	Symbol	Min.	Typ.	Max.	Unit	Test condition
Diode forward voltage	V_{SD}			1.3	V	$I_S=160\text{ A}$, $V_{GS}=0\text{ V}$
Reverse recovery time	t_{rr}		152		ns	$V_R=150\text{ V}$, $I_S=80\text{ A}$, $di/dt=100\text{ A}/\mu\text{s}$
Reverse recovery charge	Q_{rr}		0.86		μC	
Peak reverse recovery current	I_{rrm}		8.9		A	

Note

- 1) Calculated continuous current based on maximum allowable junction temperature.
- 2) Repetitive rating; pulse width limited by max. junction temperature.
- 3) P_d is based on max. junction temperature, using junction-case thermal resistance.
- 4) $V_{DD}=100\text{ V}$, $V_{GS}=10\text{ V}$, $L=80\text{ mH}$, starting $T_j=25\text{ }^\circ\text{C}$.

Electrical Characteristics Diagrams

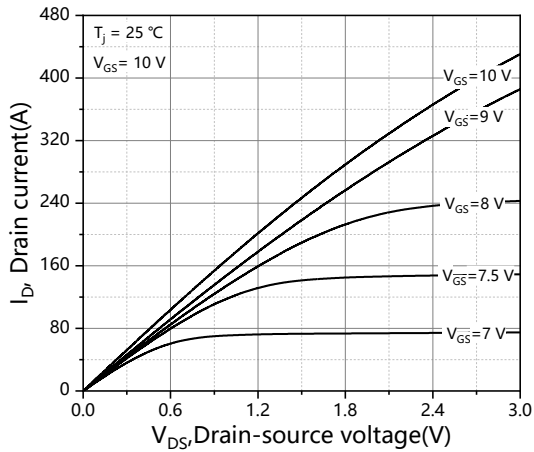

Figure 1. Typ. output characteristics $T_j=25^{\circ}\text{C}$

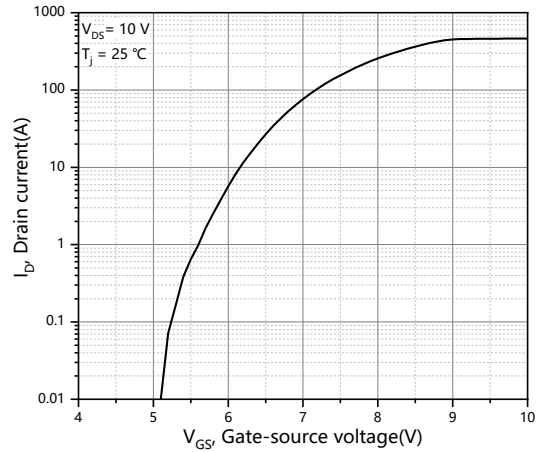

Figure 2. Typ. transfer characteristics

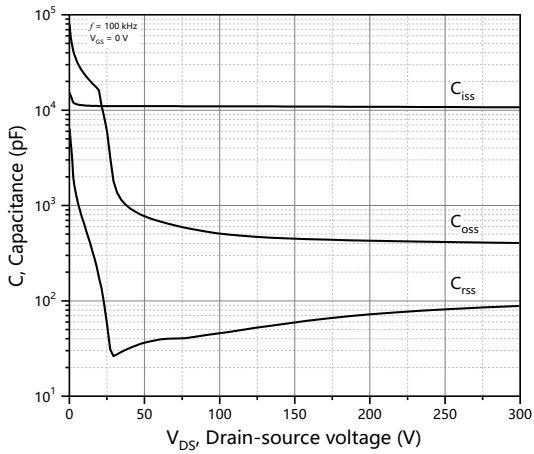

Figure 3. Typ. capacitances

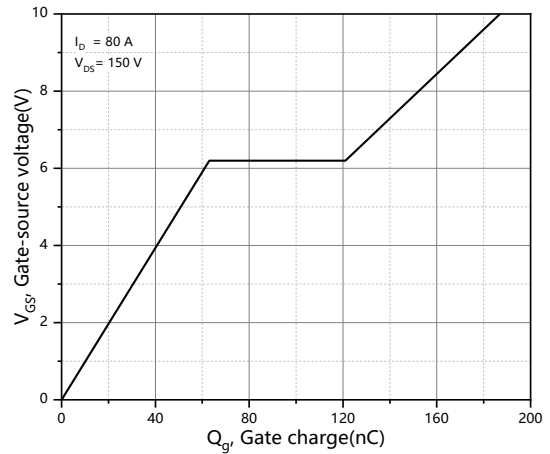

Figure 4. Typ. gate charge

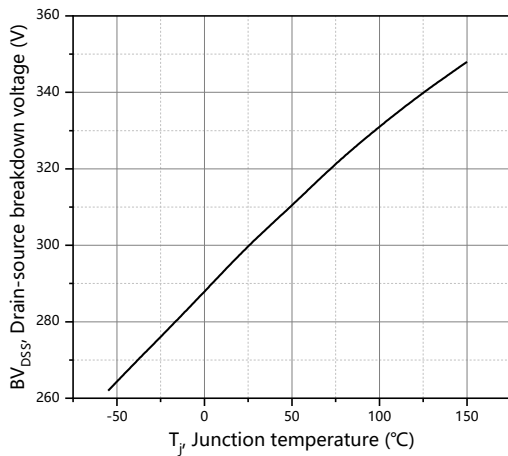

Figure 5. Drain-source breakdown voltage

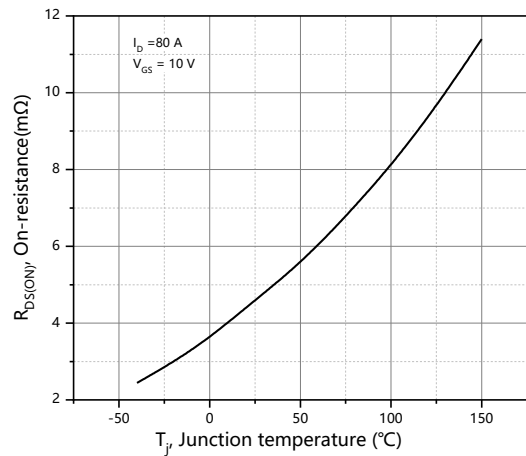
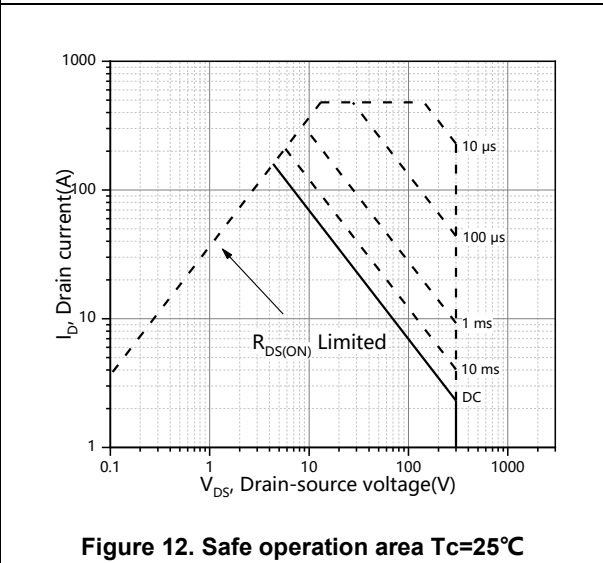
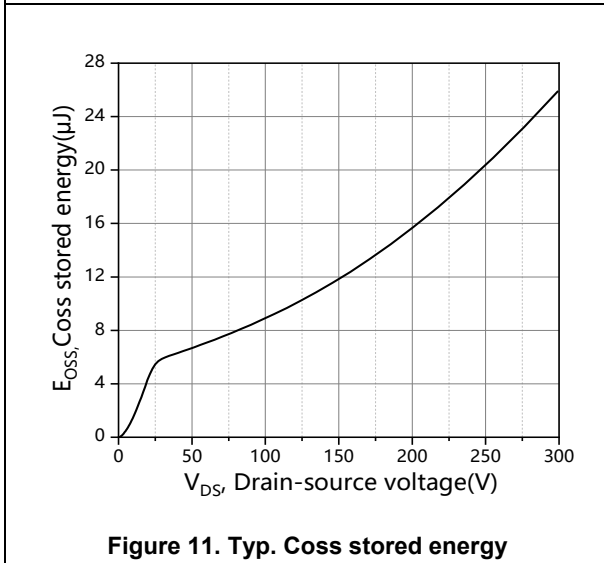
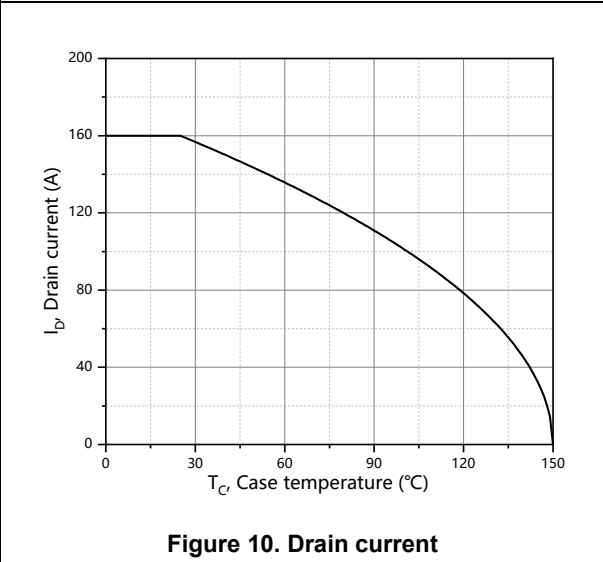
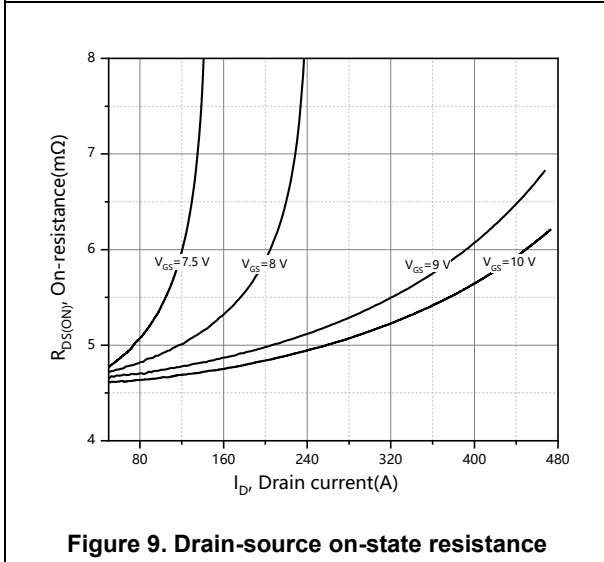
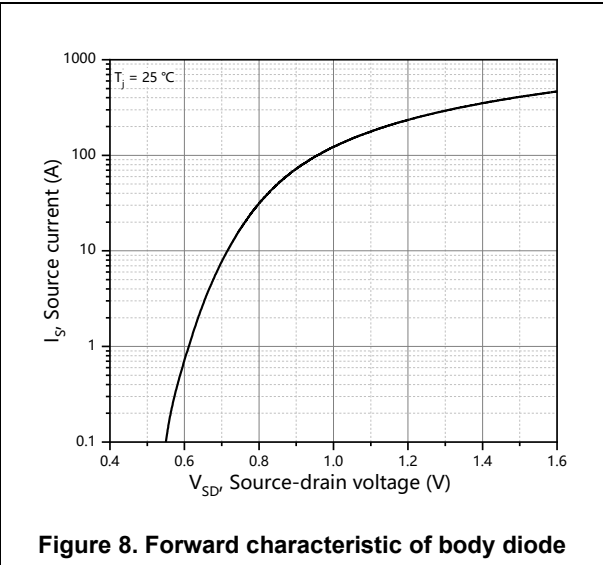
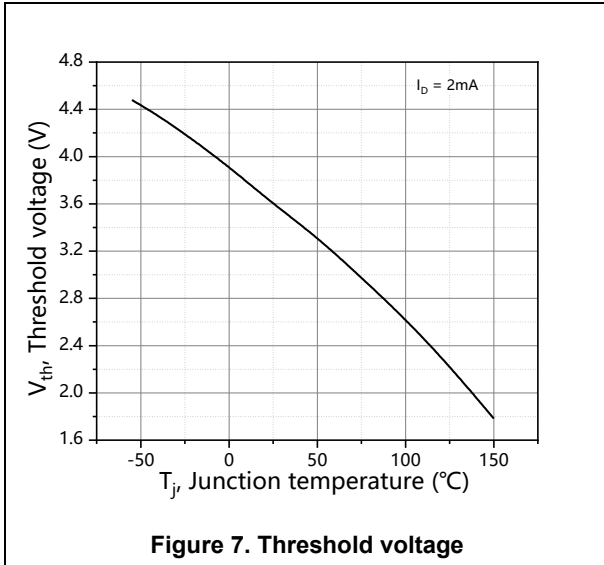
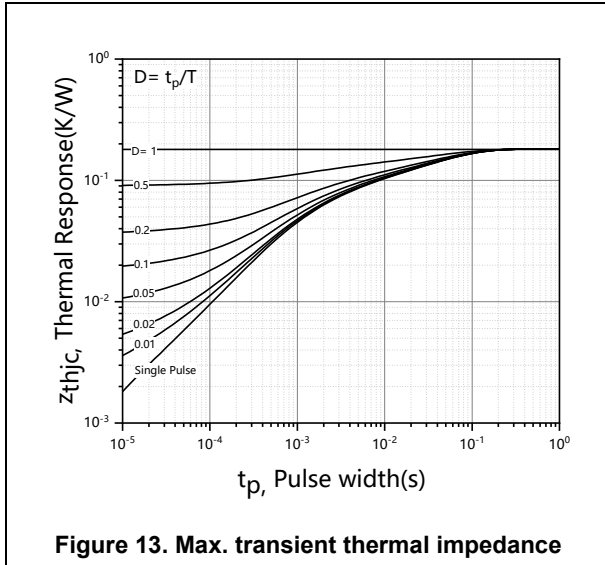

Figure 6. Drain-source on-state resistance





Test circuits and waveforms



Figure 1. Gate charge test circuit & waveform

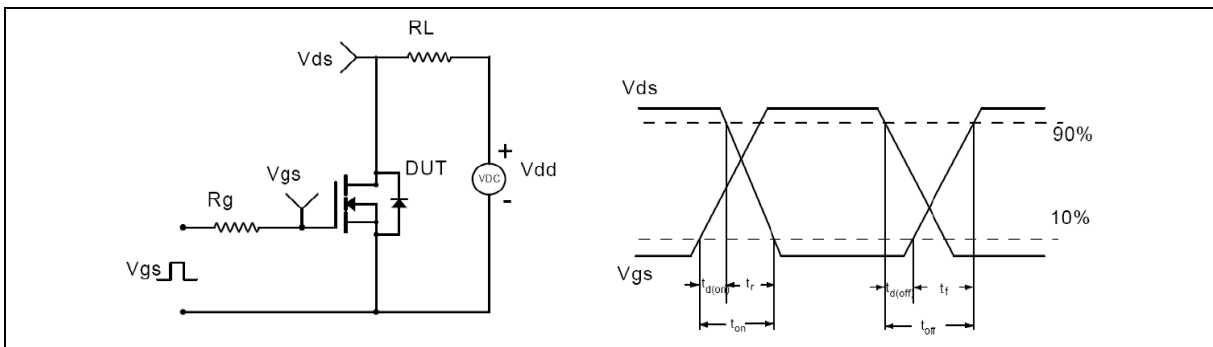

Figure 2. Switching time test circuit & waveforms

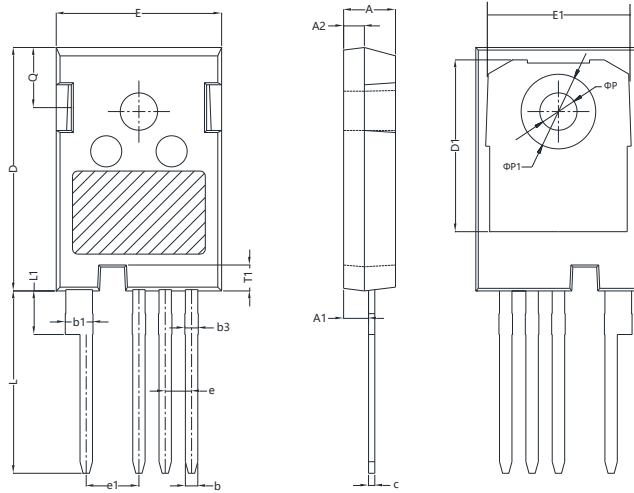

Figure 3. Unclamped inductive switching (UIS) test circuit & waveforms



Figure 4. Diode reverse recovery test circuit & waveforms

Package Information



Symbol	mm		
	Min	Nom	Max
A	4.83	5.00	5.20
A1	2.21	2.41	2.61
A2	1.80	2.00	2.20
b	1.06	1.21	1.36
b1	2.33	2.63	2.93
b3	1.07	1.30	1.60
c	0.51	0.61	0.75
D	23.30	23.45	23.60
D1	16.25	16.55	16.85
E	15.74	15.94	16.14
E1	13.72	14.02	14.32
T1	2.35	2.50	2.65
e	2.54 BSC		
e1	5.08 BSC		
Q	5.49	5.79	6.09
L	17.27	17.57	17.87
L1	3.99	4.19	4.39
ΦP	3.40	3.60	3.80
ΦP1	7.19 REF		

Version: TO247-4L-P package outline dimension

Ordering Information

Package Type	Units/ Tube	Tubes/ Inner Box	Units/ Inner Box	Inner Boxes/ Carton Box	Units/ Carton Box
TO247-4L-P	30	11	330	6	1980

Product Information

Product	Package	Pb Free	RoHS	Halogen Free
OSG30R011H4ZF	TO247-4L	yes	yes	yes

Legal Disclaimer

The information given in this document shall in no event be regarded as a guarantee of conditions or characteristics. With respect to any examples or hints given herein, any typical values stated herein and/or any information regarding the application of the device, Oriental Semiconductor hereby disclaims any and all warranties and liabilities of any kind, including without limitation, warranties of non-infringement of intellectual property rights of any third party.

For further information on technology, delivery terms and conditions and prices, please contact the Oriental Semiconductor sales representatives (www.orientalsemi.com).

© Oriental Semiconductor Co.,Ltd. All Rights Reserved /

Revision History

Version	Revision History	Date
V1.0	Initial release	2025-06-10