

General Description

OST50N65HM2F uses advanced Oriental-Semi's patented Trident-Gate Bipolar Transistor (TGBT™) technology to provide extremely low $V_{CE(sat)}$, low gate charge, and excellent switching performance. This device is suitable for mid to high range switching frequency converters.

Features

- Advanced TGBT™ technology
- Excellent conduction and switching loss
- Excellent stability and uniformity
- Fast and soft antiparallel diode



Applications

- PV inverters
- Induction converters
- Uninterruptible power supplies

Key Performance Parameters

Parameter	Value	Unit
$V_{CES, min}$ @ 25°C	650	V
Maximum junction temperature	175	°C
$I_C, pulse$	200	A
$V_{CE(sat), typ}$ @ $V_{GE}=15V$	1.55	V
Q_g	81	nC

Marking Information

Product Name	Package	Marking
OST50N65HM2F	TO247	OST50N65HM2

Package & Pin Information

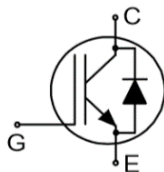

Absolute Maximum Ratings at $T_{vj}=25^{\circ}\text{C}$ unless otherwise noted

Parameter	Symbol	Value	Unit
Collector emitter voltage	V_{CES}	650	V
Gate emitter voltage	V_{GES}	± 20	V
Transient gate emitter voltage, $T_P \leq 10\mu\text{s}$, $D < 0.01$		± 30	V
Continuous collector current ¹⁾ , $T_C=25^{\circ}\text{C}$	I_C	80	A
Continuous collector current ¹⁾ , $T_C=100^{\circ}\text{C}$		50	A
Pulsed collector current ²⁾ , $T_C=25^{\circ}\text{C}$	$I_{C, pulse}$	200	A
Diode forward current ¹⁾ , $T_C=25^{\circ}\text{C}$	I_F	80	A
Diode forward current ¹⁾ , $T_C=100^{\circ}\text{C}$		50	A
Diode pulsed current ²⁾ , $T_C=25^{\circ}\text{C}$	$I_{F, pulse}$	200	A
Power dissipation ³⁾ , $T_C=25^{\circ}\text{C}$	P_D	250	W
Power dissipation ³⁾ , $T_C=100^{\circ}\text{C}$		125	W
Operation and storage temperature	T_{stg}, T_{vj}	-55 to 175	$^{\circ}\text{C}$

Thermal Characteristics

Parameter	Symbol	Value	Unit
IGBT thermal resistance, junction-case	$R_{\theta JC}$	0.4	$^{\circ}\text{C}/\text{W}$
Diode thermal resistance, junction-case	$R_{\theta JC}$	0.38	$^{\circ}\text{C}/\text{W}$
Thermal resistance, junction-ambient	$R_{\theta JA}$	40	$^{\circ}\text{C}/\text{W}$

Electrical Characteristics at $T_{vj}=25^{\circ}\text{C}$ unless otherwise specified

Parameter	Symbol	Min.	Typ.	Max.	Unit	Test condition
Collector-emitter breakdown voltage	$V_{(BR)CES}$	650			V	$V_{GE}=0\text{ V}$, $I_C=0.5\text{ mA}$
Collector-emitter saturation voltage	$V_{CE(sat)}$		1.55	1.85	V	$V_{GE}=15\text{ V}$, $I_C=50\text{ A}$ $T_{vj}=25^{\circ}\text{C}$
			1.77		V	$V_{GE}=15\text{ V}$, $I_C=50\text{ A}$, $T_{vj}=125^{\circ}\text{C}$
			1.90			$V_{GE}=15\text{ V}$, $I_C=50\text{ A}$, $T_{vj}=175^{\circ}\text{C}$
Gate-emitter threshold voltage	$V_{GE(th)}$	3.5	4.5	5.5	V	$V_{CE}=V_{GE}$, $I_D=0.5\text{ mA}$
Diode forward voltage	V_F		1.55	1.85	V	$V_{GE}=0\text{ V}$, $I_F=50\text{ A}$ $T_{vj}=25^{\circ}\text{C}$
			1.39			$V_{GE}=0\text{ V}$, $I_F=50\text{ A}$, $T_{vj}=125^{\circ}\text{C}$
			1.32			$V_{GE}=0\text{ V}$, $I_F=50\text{ A}$, $T_{vj}=175^{\circ}\text{C}$
Gate-emitter leakage current	I_{GES}			100	nA	$V_{CE}=0\text{ V}$, $V_{GE}=20\text{ V}$
Zero gate voltage collector current	I_{CES}			10	μA	$V_{CE}=650\text{ V}$, $V_{GE}=0\text{ V}$

Dynamic Characteristics

Parameter	Symbol	Min.	Typ.	Max.	Unit	Test condition
Input capacitance	C_{ies}		4345		pF	$V_{GE}=0\text{ V}$, $V_{CE}=25\text{ V}$, $f=100\text{ kHz}$
Output capacitance	C_{oes}		149		pF	
Reverse transfer capacitance	C_{res}		4.7		pF	
Turn-on delay time	$t_{d(on)}$		47		ns	$V_{GE}=15\text{ V}$, $V_{CC}=400\text{ V}$, $R_G=10\ \Omega$, $I_C=50\text{ A}$
Rise time	t_r		69		ns	
Turn-off delay time	$t_{d(off)}$		124		ns	
Fall time	t_f		56		ns	
Turn-on energy	E_{on}		1.55		mJ	
Turn-off energy	E_{off}		0.56		mJ	
Turn-on delay time	$t_{d(on)}$		45		ns	$V_{GE}=15\text{ V}$, $V_{CC}=400\text{ V}$, $R_G=10\ \Omega$, $I_C=25\text{ A}$
Rise time	t_r		33		ns	
Turn-off delay time	$t_{d(off)}$		151		ns	
Fall time	t_f		51		ns	
Turn-on energy	E_{on}		0.58		mJ	
Turn-off energy	E_{off}		0.27		mJ	

Gate Charge Characteristics

Parameter	Symbol	Min.	Typ.	Max.	Unit	Test condition
Total gate charge	Q_g		81		nC	$V_{GE}=15\text{ V}$, $V_{CC}=520\text{ V}$, $I_C=50\text{ A}$
Gate-emitter charge	Q_{ge}		34		nC	
Gate-collector charge	Q_{gc}		15		nC	

Body Diode Characteristics

Parameter	Symbol	Min.	Typ.	Max.	Unit	Test condition
Diode reverse recovery time	t_{rr}		86		ns	$V_R=400\text{ V}$, $I_F=50\text{ A}$, $di_F/dt=500\text{ A}/\mu\text{s}$ $T_{vj}=25^\circ\text{C}$
Diode reverse recovery charge	Q_{rr}		971		nC	
Diode peak reverse recovery current	I_{rrm}		17.8		A	

Note

- 1) Calculated continuous current based on maximum allowable junction temperature.
- 2) Repetitive rating; pulse width limited by max. junction temperature.
- 3) P_d is based on max. junction temperature, using junction-case thermal resistance.

Electrical Characteristics Diagrams

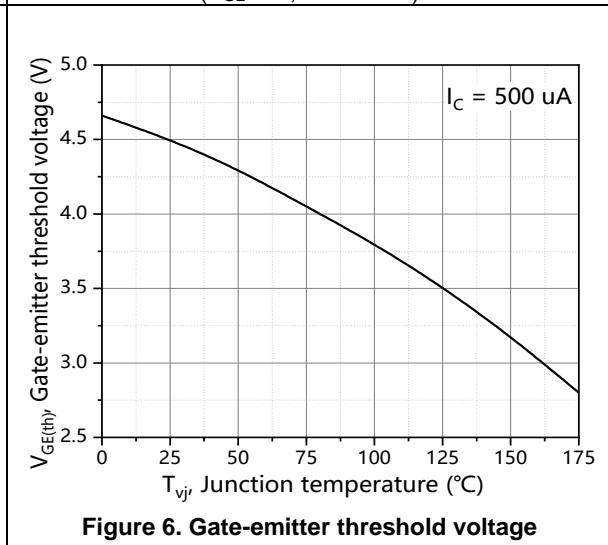
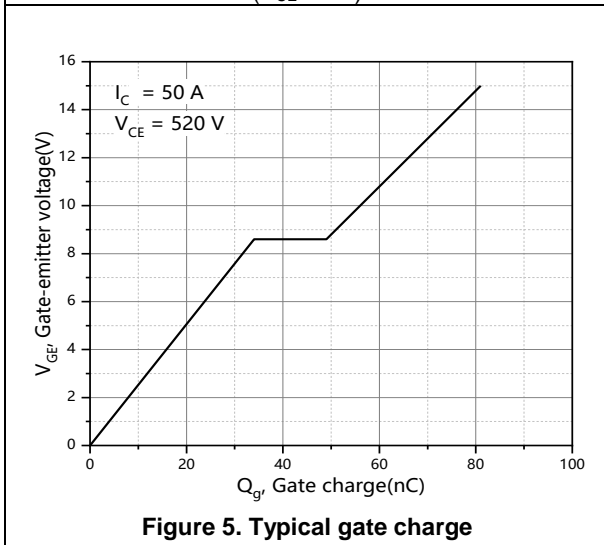
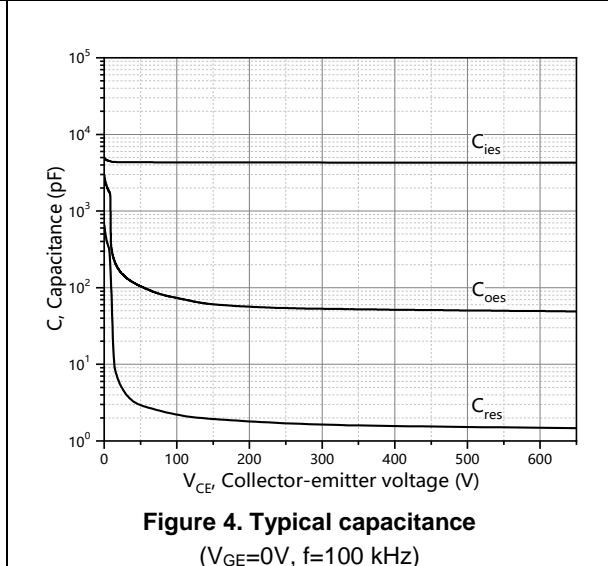
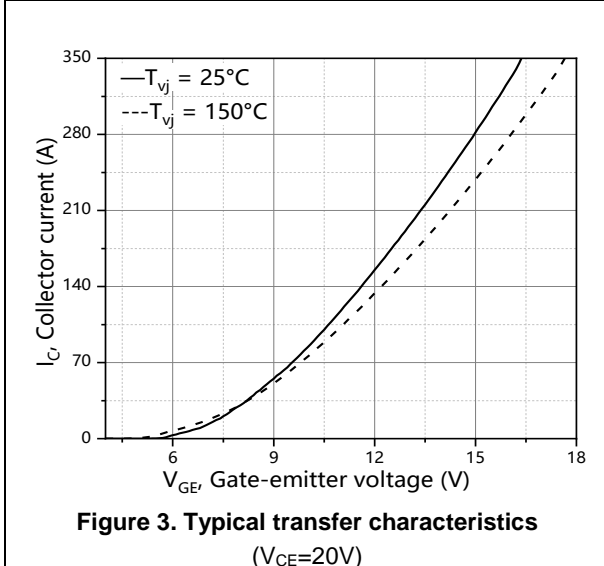
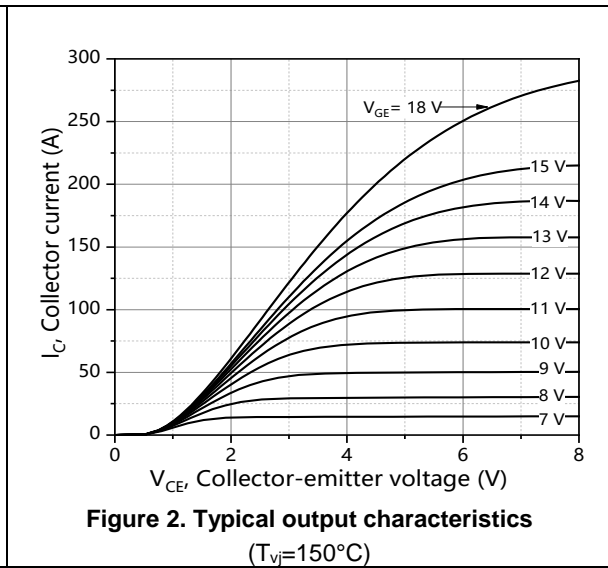
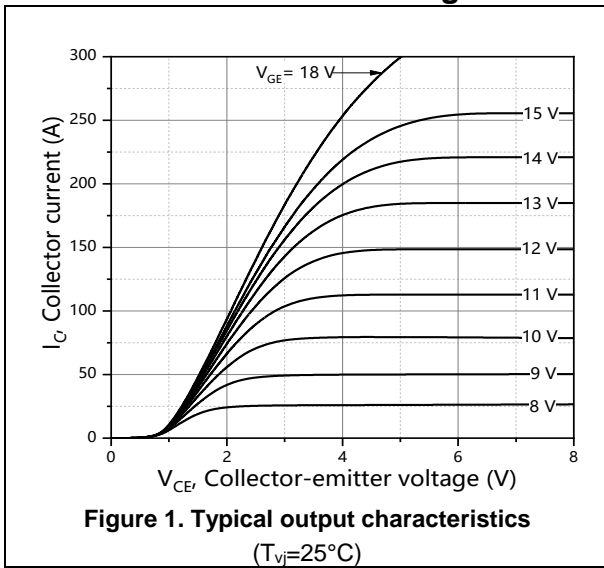

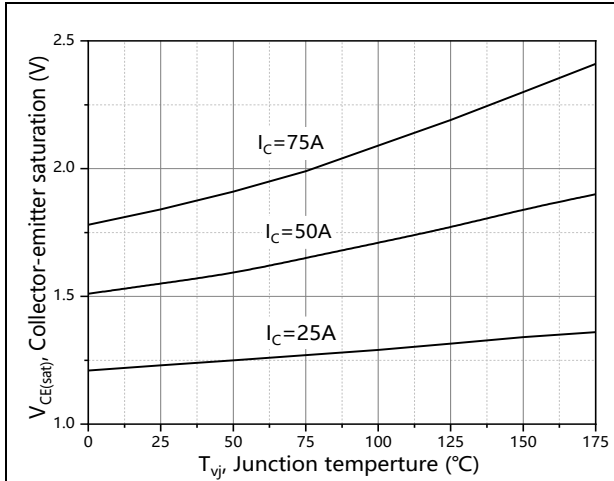

Figure 7. Typical collector-emitter voltage

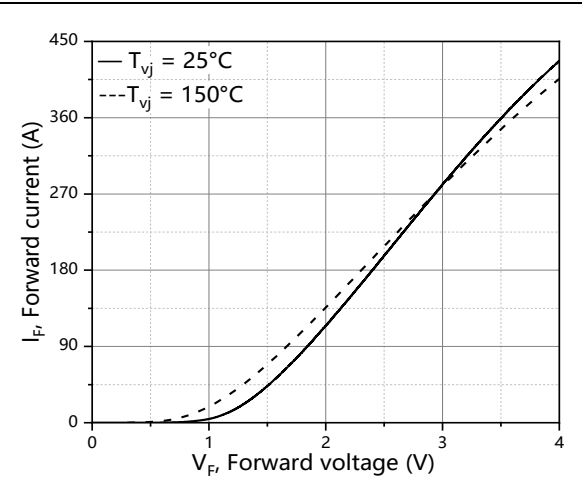

Figure 8. Forward characteristic of diode

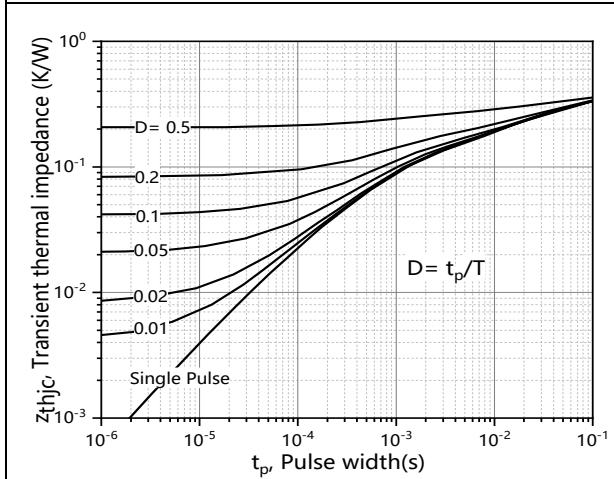

Figure 9. IGBT transient thermal impedance

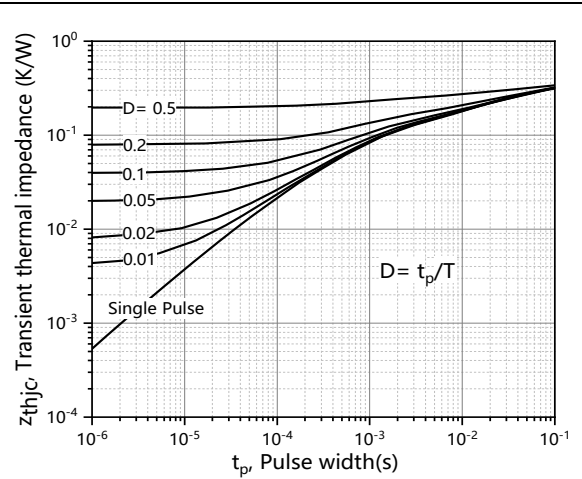
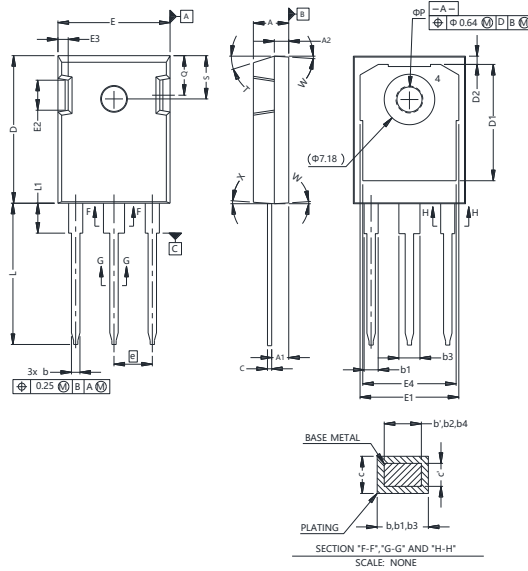

Figure 10. Diode transient thermal impedance

Package Information



Symbol	mm	
	Min	Max
A	4.83	5.21
A1	2.29	2.54
A2	1.91	2.16
b'	1.07	1.28
b	1.07	1.33
b1	1.91	2.41
b2	1.91	2.16
b3	2.87	3.38
b4	2.87	3.13
c'	0.55	0.65
c	0.55	0.68
D	20.80	21.10
D1	16.25	17.65
D2	0.95	1.25
E	15.75	16.13
E1	13.10	14.15
E2	3.68	5.10
E3	1.00	1.90
E4	12.38	13.43
e	5.44 BSC	
N	3	
L	19.81	20.32
L1	4.10	4.40
øP	3.51	3.65
Q	5.49	6.00
S	6.04	6.30
T	17.5° REF	
W	3.5° REF	
X	4° REF	

Version 1: TO247-S package outline dimension

Ordering Information

Package Type	Units/ Tube	Tubes/ Inner Box	Units/ Inner Box	Inner Boxes/ Carton Box	Units/ Carton Box
TO247-S	30	15	450	4	1800

Product Information

Product	Package	Pb Free	RoHS	Halogen Free
OST50N65HM2F	TO247	yes	yes	yes

Legal Disclaimer

The information given in this document shall in no event be regarded as a guarantee of conditions or characteristics. With respect to any examples or hints given herein, any typical values stated herein and/or any information regarding the application of the device, Oriental Semiconductor hereby disclaims any and all warranties and liabilities of any kind, including without limitation, warranties of non-infringement of intellectual property rights of any third party.

For further information on technology, delivery terms and conditions and prices, please contact the Oriental Semiconductor sales representatives (www.orientalsemi.com).

© Oriental Semiconductor Co.,Ltd. All Rights Reserved 