

General Description

FSMOS[®] MOSFET is based on Oriental Semiconductor's unique device design to achieve low $R_{DS(ON)}$, low gate charge, fast switching and excellent avalanche characteristics. The high V_{th} series is specially designed to use in motor control systems with driving voltage of more than 10V.

Features

- Low $R_{DS(ON)}$ & FOM
- Extremely low switching loss
- Excellent reliability and uniformity
- Fast switching and soft recovery



Applications

- PD charger
- Motor driver
- Switching voltage regulator
- DC-DC convertor
- Switching mode power supply

Key Performance Parameters

| Parameter | Value | Unit |
|--------------------------------|-------|------------|
| V_{DS} | 80 | V |
| $I_{D, pulse}$ | 800 | A |
| $R_{DS(ON), max @ V_{GS}=10V}$ | 1.7 | m Ω |
| Q_g | 106.5 | nC |
| PD | 270 | W |

Marking Information

| Product Name | Package | Marking |
|--------------|---------|-------------|
| SFS08R017HNF | TO247 | SFS08R017HN |

Package & Pin information

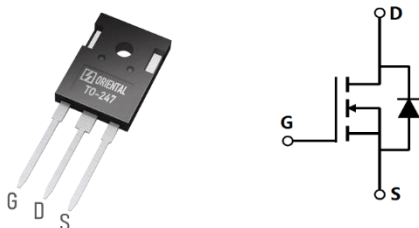

Absolute Maximum Ratings at $T_j=25^{\circ}\text{C}$ unless otherwise noted

| Parameter | Symbol | Value | Unit |
|---|----------------|------------|--------------------|
| Drain-source voltage | V_{DS} | 80 | V |
| Gate-source voltage | V_{GS} | ± 20 | V |
| Continuous drain current ¹⁾ , $T_C=25^{\circ}\text{C}$ | I_D | 300 | A |
| Pulsed drain current ²⁾ , $T_C=25^{\circ}\text{C}$ | $I_{D, pulse}$ | 800 | A |
| Continuous diode forward current ¹⁾ , $T_C=25^{\circ}\text{C}$ | I_S | 300 | A |
| Diode pulsed current ²⁾ , $T_C=25^{\circ}\text{C}$ | $I_{S, pulse}$ | 800 | A |
| Power dissipation ³⁾ , $T_C=25^{\circ}\text{C}$ | P_D | 270 | W |
| Single pulsed avalanche energy ⁴⁾ | E_{AS} | 1699 | mJ |
| Operation and storage temperature | T_{stg}, T_j | -55 to 150 | $^{\circ}\text{C}$ |

Thermal Characteristics

| Parameter | Symbol | Value | Unit |
|--------------------------------------|-----------------|-------|----------------------|
| Thermal resistance, junction-case | $R_{\theta JC}$ | 0.46 | $^{\circ}\text{C/W}$ |
| Thermal resistance, junction-ambient | $R_{\theta JA}$ | 62 | $^{\circ}\text{C/W}$ |

Electrical Characteristics at $T_j=25^{\circ}\text{C}$ unless otherwise specified

| Parameter | Symbol | Min. | Typ. | Max. | Unit | Test condition |
|----------------------------------|--------------|------|------|------|---------------|---|
| Drain-source breakdown voltage | BV_{DSS} | 80 | | | V | $V_{GS}=0\text{ V}, I_D=250\ \mu\text{A}$ |
| Gate threshold voltage | $V_{GS(th)}$ | 2.0 | | 4.0 | V | $V_{DS}=V_{GS}, I_D=250\ \mu\text{A}$ |
| Drain-source on-state resistance | $R_{DS(ON)}$ | | 1.5 | 1.7 | m Ω | $V_{GS}=10\text{ V}, I_D=50\text{ A}$ |
| Gate-source leakage current | I_{GSS} | | | 100 | nA | $V_{GS}=20\text{ V}$ |
| | | | | -100 | | $V_{GS}=-20\text{ V}$ |
| Drain-source leakage current | I_{DSS} | | | 1 | μA | $V_{DS}=80\text{ V}, V_{GS}=0\text{ V}$ |
| Gate resistance | R_G | | 1.3 | | Ω | $f=1\text{ MHz}$, Open drain |

Dynamic Characteristics

| Parameter | Symbol | Min. | Typ. | Max. | Unit | Test condition |
|------------------------------|--------------|------|--------|------|------|--|
| Input capacitance | C_{iss} | | 7550.1 | | pF | $V_{GS}=0\text{ V}$, $V_{DS}=40\text{ V}$, $f=100\text{ kHz}$ |
| Output capacitance | C_{oss} | | 2800.7 | | pF | |
| Reverse transfer capacitance | C_{rss} | | 96.9 | | pF | |
| Turn-on delay time | $t_{d(on)}$ | | 26.8 | | ns | $V_{GS}=10\text{ V}$, $V_{DS}=40\text{ V}$, $R_G=2\ \Omega$, $I_D=50\text{ A}$ |
| Rise time | t_r | | 16.0 | | ns | |
| Turn-off delay time | $t_{d(off)}$ | | 46.8 | | ns | |
| Fall time | t_f | | 20.0 | | ns | |

Gate Charge Characteristics

| Parameter | Symbol | Min. | Typ. | Max. | Unit | Test condition |
|----------------------|---------------|------|-------|------|------|---|
| Total gate charge | Q_g | | 106.5 | | nC | $V_{GS}=10\text{ V}$, $V_{DS}=40\text{ V}$, $I_D=50\text{ A}$ |
| Gate-source charge | Q_{gs} | | 32.6 | | nC | |
| Gate-drain charge | Q_{gd} | | 23.5 | | nC | |
| Gate plateau voltage | $V_{plateau}$ | | 4.8 | | V | |

Body Diode Characteristics

| Parameter | Symbol | Min. | Typ. | Max. | Unit | Test condition |
|-------------------------------|-----------|------|-------|------|------|--|
| Diode forward voltage | V_{SD} | | | 1.1 | V | $I_S=50\text{ A}$, $V_{GS}=0\text{ V}$ |
| Reverse recovery time | t_{rr} | | 47.7 | | ns | $V_R=40\text{ V}$, $I_S=50\text{ A}$, $di/dt=400\text{ A}/\mu\text{s}$ |
| Reverse recovery charge | Q_{rr} | | 181.5 | | nC | |
| Peak reverse recovery current | I_{rrm} | | 6.4 | | A | |

Note

- 1) Calculated continuous current based on maximum allowable junction temperature.
- 2) Repetitive rating; pulse width limited by max. junction temperature.
- 3) P_d is based on max. junction temperature, using junction-case thermal resistance.
- 4) $V_{DD}=50\text{ V}$, $V_{GS}=10\text{ V}$, $L=0.3\text{ mH}$, starting $T_j=25\text{ }^\circ\text{C}$.

Electrical Characteristics Diagrams

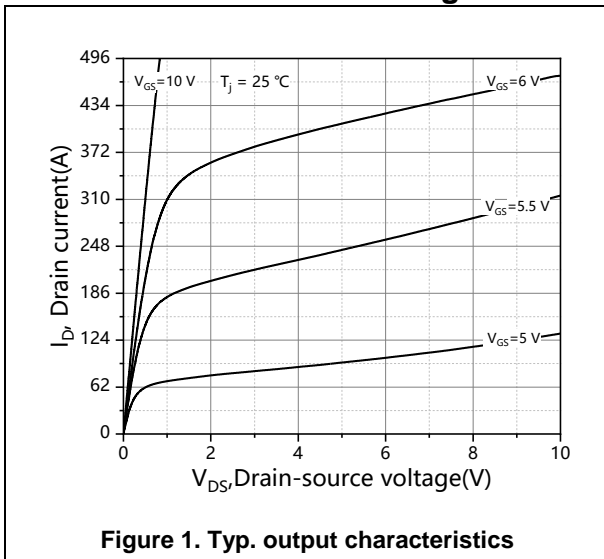

Figure 1. Typ. output characteristics

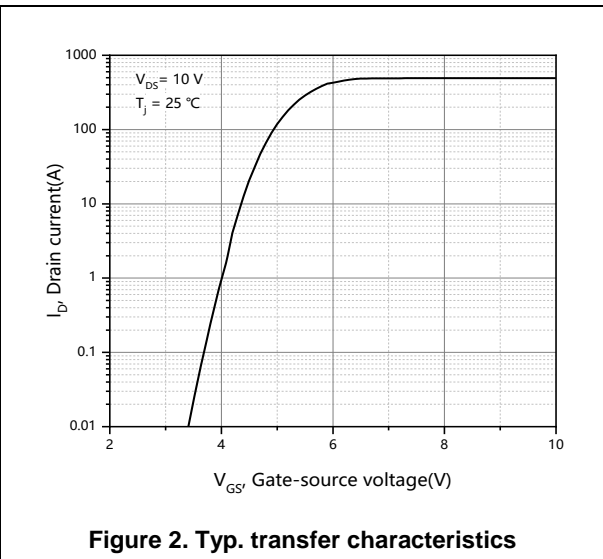

Figure 2. Typ. transfer characteristics

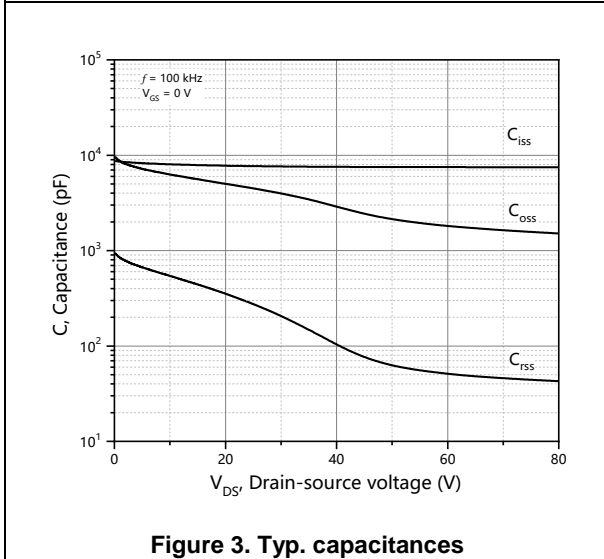

Figure 3. Typ. capacitances

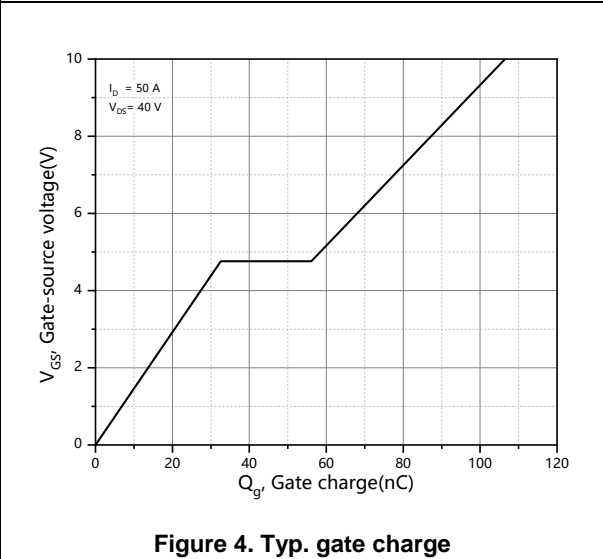

Figure 4. Typ. gate charge

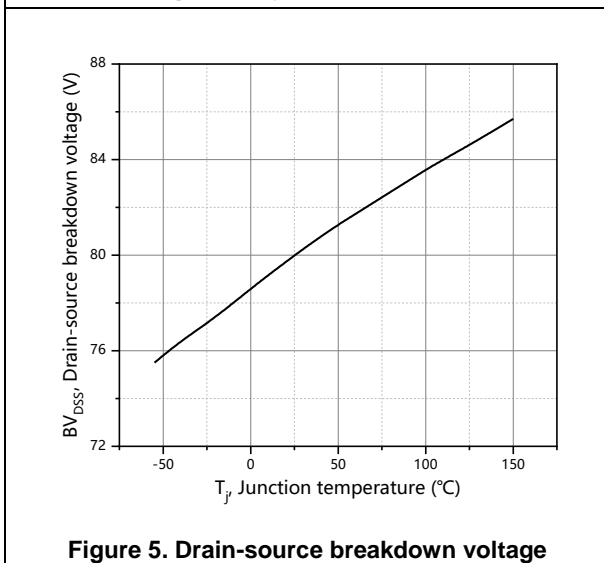

Figure 5. Drain-source breakdown voltage

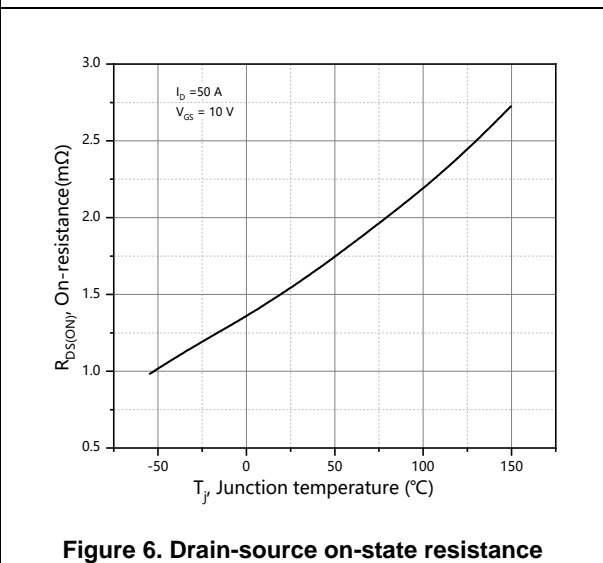

Figure 6. Drain-source on-state resistance

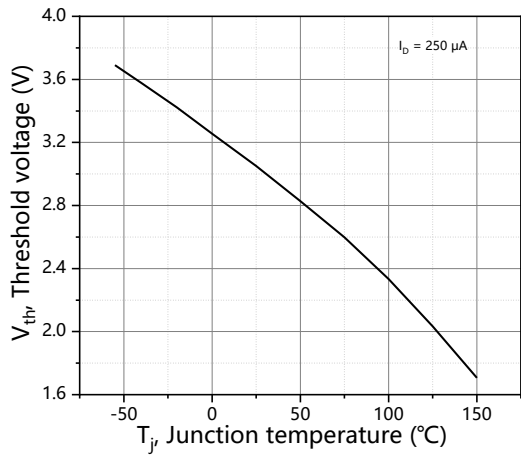

Figure 7. Threshold voltage

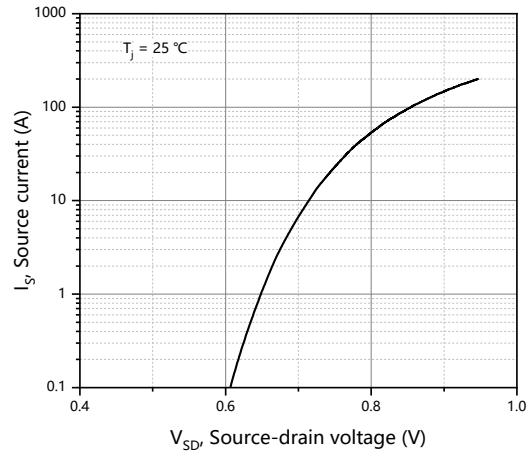

Figure 8. Forward characteristic of body diode

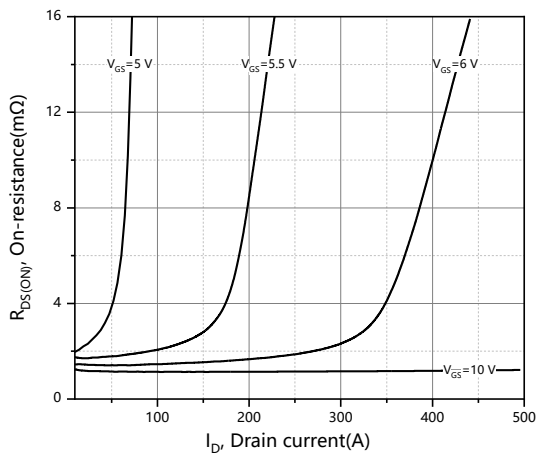

Figure 9. Drain-source on-state resistance

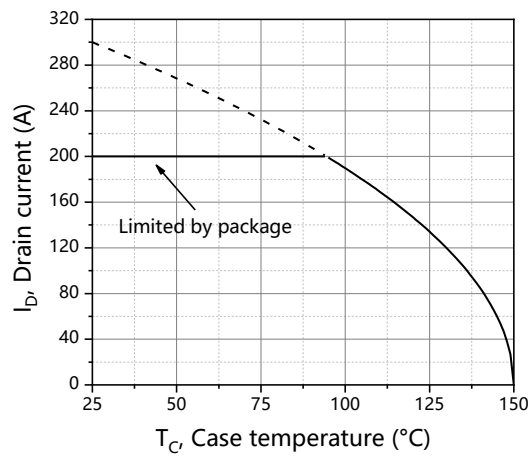

Figure 10. Drain current

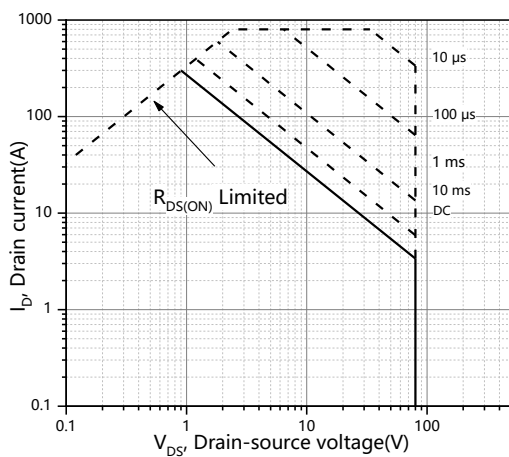

Figure 11. Safe operation area T_C=25°C

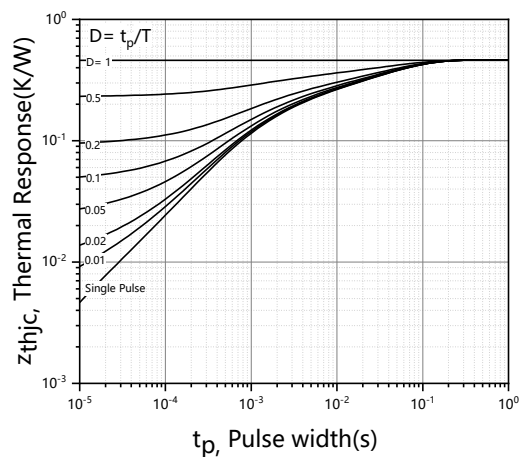

Figure 12. Max. transient thermal impedance

Test circuits and waveforms



Figure 1. Gate charge test circuit & waveform



Figure 2. Switching time test circuit & waveforms

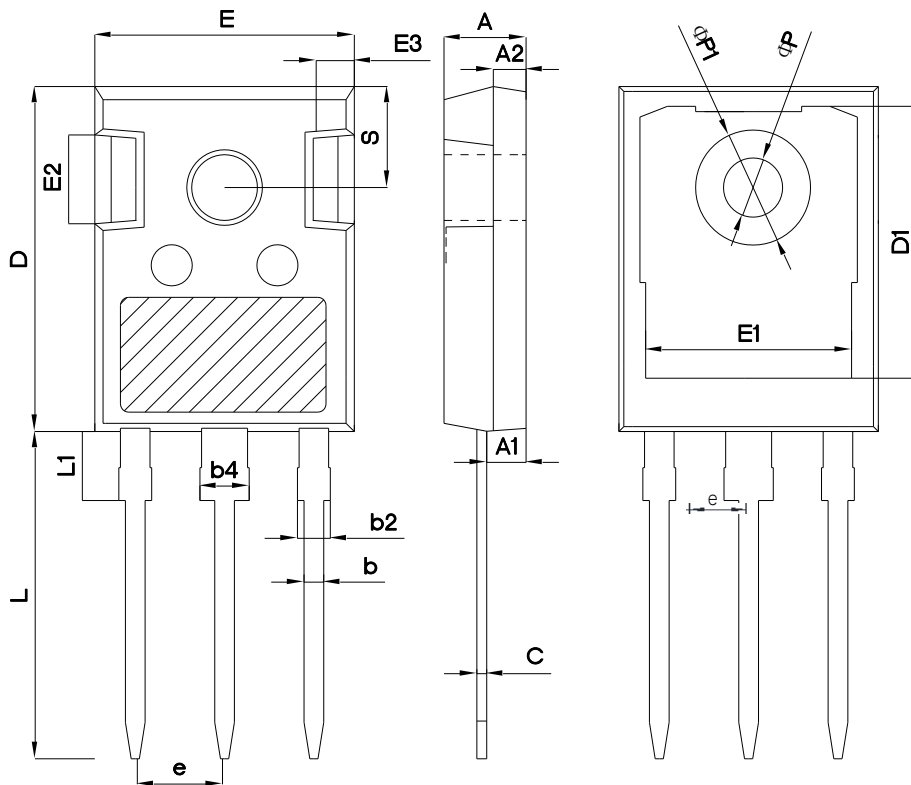

Figure 3. Unclamped inductive switching (UIS) test circuit & waveforms



Figure 4. Diode reverse recovery test circuit & waveforms

Package Information



| Symbol | mm | | |
|--------|----------|-------|-------|
| | Min | Nom | Max |
| A | 4.80 | 5.00 | 5.20 |
| A1 | 2.21 | 2.41 | 2.59 |
| A2 | 1.85 | 2.00 | 2.15 |
| b | 1.11 | 1.21 | 1.36 |
| b2 | 1.91 | 2.01 | 2.21 |
| b4 | 2.91 | 3.01 | 3.21 |
| c | 0.51 | 0.61 | 0.75 |
| D | 20.80 | 21.00 | 21.30 |
| D1 | 16.25 | 16.55 | 16.85 |
| E | 15.50 | 15.80 | 16.10 |
| E1 | 13.00 | 13.30 | 13.60 |
| E2 | 4.80 | 5.00 | 5.20 |
| E3 | 2.30 | 2.50 | 2.70 |
| e | 5.44 BSC | | |
| L | 19.82 | 19.92 | 20.22 |
| L1 | - | - | 4.30 |
| ΦP | 3.40 | 3.60 | 3.80 |
| ΦP1 | - | - | 7.30 |
| S | 6.15 BSC | | |

Version : TO247-P package outline dimension

Ordering Information

| Package Type | Units/ Tube | Tubes / Inner Box | Units/ Inner Box | Inner Boxes/ Carton Box | Units/ Carton Box |
|--------------|-------------|-------------------|------------------|-------------------------|-------------------|
| TO247-P | 30 | 11 | 330 | 6 | 1980 |

Product Information

| Product | Package | Pb Free | RoHS | Halogen Free |
|--------------|---------|---------|------|--------------|
| SFS08R017HNF | TO247 | yes | yes | yes |

Legal Disclaimer

The information given in this document shall in no event be regarded as a guarantee of conditions or characteristics. With respect to any examples or hints given herein, any typical values stated herein and/or any information regarding the application of the device, Oriental Semiconductor hereby disclaims any and all warranties and liabilities of any kind, including without limitation, warranties of non-infringement of intellectual property rights of any third party.

For further information on technology, delivery terms and conditions and prices, please contact the Oriental Semiconductor sales representatives (www.orientalsemi.com).

© Oriental Semiconductor Co.,Ltd. All Rights Reserved /