

General Description

FSMOS[®] MOSFET is based on Oriental Semiconductor's unique device design to achieve low $R_{DS(ON)}$, low gate charge, fast switching and excellent avalanche characteristics. The low V_{th} series is specially optimized for synchronous rectification systems with low driving voltage.

Features

- Low $R_{DS(ON)}$ & FOM
- Extremely low switching loss
- Excellent reliability and uniformity
- Fast switching and soft recovery



Applications

- PD charger
- Motor driver
- Switching voltage regulator
- DC-DC convertor
- Switching mode power supply

Key Performance Parameters

| Parameter | Value | Unit |
|-----------------------------------|-------|------------|
| V_{DS} | 80 | V |
| I_D , pulse | 140 | A |
| $R_{DS(ON)}$, max @ $V_{GS}=10V$ | 20 | m Ω |
| Q_g | 13 | nC |

Marking Information

| Product Name | Package | Marking |
|--------------|---------|-----------|
| SFS08R20GF | PDFN5x6 | SFS08R20G |

Package & Pin information

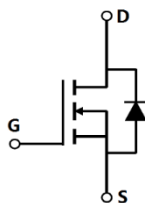

Absolute Maximum Ratings at $T_j=25^{\circ}\text{C}$ unless otherwise noted

| Parameter | Symbol | Value | Unit |
|---|----------------|------------|--------------------|
| Drain-source voltage | V_{DS} | 80 | V |
| Gate-source voltage | V_{GS} | ± 20 | V |
| Continuous drain current ¹⁾ , $T_C=25^{\circ}\text{C}$ | I_D | 35 | A |
| Pulsed drain current ²⁾ , $T_C=25^{\circ}\text{C}$ | $I_{D, pulse}$ | 140 | A |
| Continuous diode forward current ¹⁾ , $T_C=25^{\circ}\text{C}$ | I_S | 35 | A |
| Diode pulsed current ²⁾ , $T_C=25^{\circ}\text{C}$ | $I_{S, pulse}$ | 140 | A |
| Power dissipation ³⁾ , $T_C=25^{\circ}\text{C}$ | P_D | 35 | W |
| Single pulsed avalanche energy ⁵⁾ | E_{AS} | 22 | mJ |
| Operation and storage temperature | T_{stg}, T_j | -55 to 175 | $^{\circ}\text{C}$ |

Thermal Characteristics

| Parameter | Symbol | Value | Unit |
|--|-----------------|-------|----------------------|
| Thermal resistance, junction-case | $R_{\theta JC}$ | 4.3 | $^{\circ}\text{C/W}$ |
| Thermal resistance, junction-ambient ⁴⁾ | $R_{\theta JA}$ | 62 | $^{\circ}\text{C/W}$ |

Electrical Characteristics at $T_j=25^{\circ}\text{C}$ unless otherwise specified

| Parameter | Symbol | Min. | Typ. | Max. | Unit | Test condition |
|----------------------------------|--------------|------|------|------|---------------|---|
| Drain-source breakdown voltage | BV_{DSS} | 80 | | | V | $V_{GS}=0\text{ V}, I_D=250\ \mu\text{A}$ |
| Gate threshold voltage | $V_{GS(th)}$ | 1.3 | | 2 | V | $V_{DS}=V_{GS}, I_D=250\ \mu\text{A}$ |
| Drain-source on-state resistance | $R_{DS(ON)}$ | | 15 | 20 | m Ω | $V_{GS}=10\text{ V}, I_D=12\text{A}$ |
| Drain-source on-state resistance | $R_{DS(ON)}$ | | 20 | 25 | m Ω | $V_{GS}=4.5\text{ V}, I_D=9\text{ A}$ |
| Gate-source leakage current | I_{GSS} | | | 100 | nA | $V_{GS}=20\text{ V}$ |
| | | | | -100 | | $V_{GS}=-20\text{ V}$ |
| Drain-source leakage current | I_{DSS} | | | 1 | μA | $V_{DS}=80\text{ V}, V_{GS}=0\text{ V}$ |
| Gate resistance | R_G | | 2.8 | | Ω | $f=1\text{ MHz}, \text{Open drain}$ |

Dynamic Characteristics

| Parameter | Symbol | Min. | Typ. | Max. | Unit | Test condition |
|------------------------------|--------------|------|------|------|------|--|
| Input capacitance | C_{iss} | | 792 | | pF | $V_{GS}=0\text{ V}$, $V_{DS}=25\text{ V}$, $f=100\text{ kHz}$ |
| Output capacitance | C_{oss} | | 342 | | pF | |
| Reverse transfer capacitance | C_{rss} | | 29 | | pF | |
| Turn-on delay time | $t_{d(on)}$ | | 7 | | ns | $V_{GS}=10\text{ V}$, $V_{DS}=40\text{ V}$, $R_G=2\ \Omega$, $I_D=20\text{ A}$ |
| Rise time | t_r | | 4 | | ns | |
| Turn-off delay time | $t_{d(off)}$ | | 17 | | ns | |
| Fall time | t_f | | 2.6 | | ns | |

Gate Charge Characteristics

| Parameter | Symbol | Min. | Typ. | Max. | Unit | Test condition |
|----------------------|---------------|------|------|------|------|---|
| Total gate charge | Q_g | | 13 | | nC | $V_{GS}=10\text{ V}$, $V_{DS}=40\text{ V}$, $I_D=20\text{ A}$ |
| Gate-source charge | Q_{gs} | | 2.4 | | nC | |
| Gate-drain charge | Q_{gd} | | 2.5 | | nC | |
| Gate plateau voltage | $V_{plateau}$ | | 3.4 | | V | |

Body Diode Characteristics

| Parameter | Symbol | Min. | Typ. | Max. | Unit | Test condition |
|-------------------------------|-----------|------|------|------|------|--|
| Diode forward voltage | V_{SD} | | | 1.3 | V | $I_S=20\text{ A}$, $V_{GS}=0\text{ V}$ |
| Reverse recovery time | t_{rr} | | 40 | | ns | $V_R=40\text{ V}$, $I_S=20\text{ A}$, $di/dt=100\text{ A}/\mu\text{s}$ |
| Reverse recovery charge | Q_{rr} | | 35 | | nC | |
| Peak reverse recovery current | I_{rrm} | | 1.6 | | A | |

Note

- 1) Calculated continuous current based on maximum allowable junction temperature.
- 2) Repetitive rating; pulse width limited by max. junction temperature.
- 3) P_d is based on max. junction temperature, using junction-case thermal resistance.
- 4) The value of $R_{\theta JA}$ is measured with the device mounted on 1 in² FR-4 board with 2oz. Copper, in a still air environment with $T_a=25\text{ }^\circ\text{C}$.
- 5) $V_{DD}=50\text{ V}$, $V_{GS}=10\text{ V}$, $L=0.3\text{ mH}$, starting $T_j=25\text{ }^\circ\text{C}$.

Electrical Characteristics Diagrams

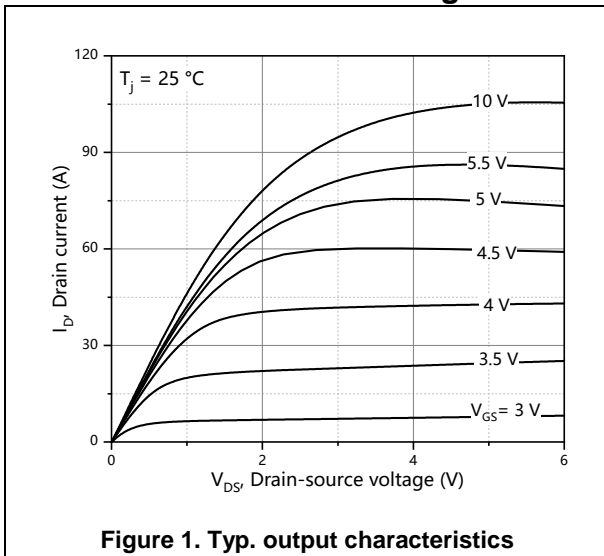

Figure 1. Typ. output characteristics

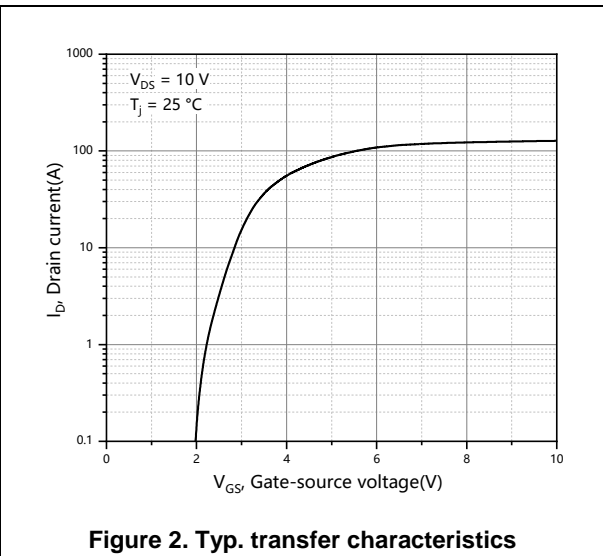

Figure 2. Typ. transfer characteristics

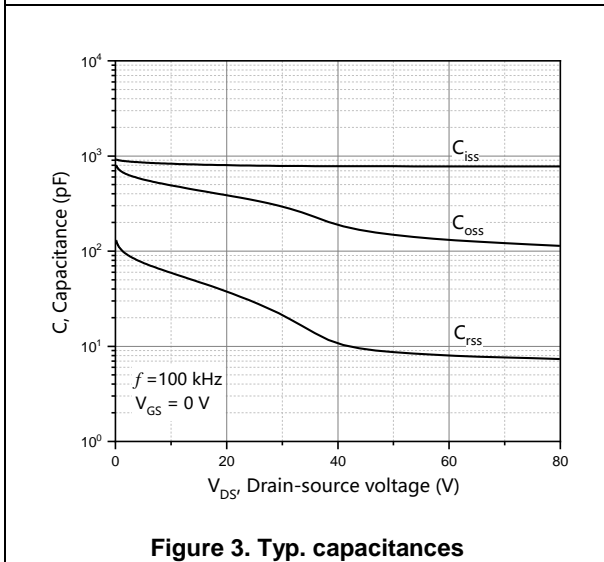

Figure 3. Typ. capacitances

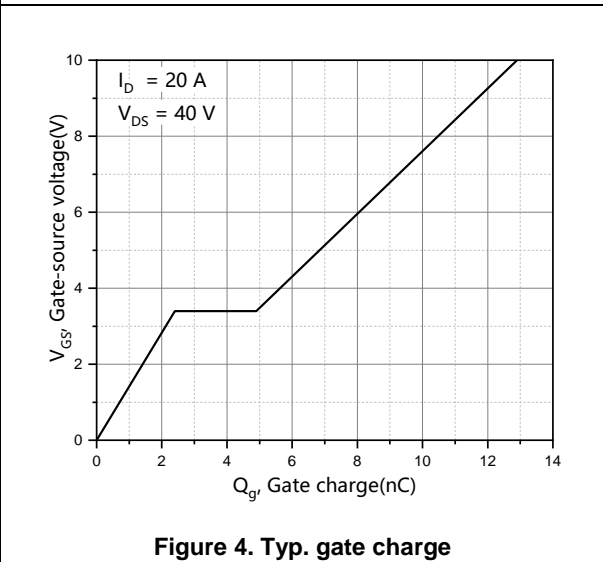

Figure 4. Typ. gate charge

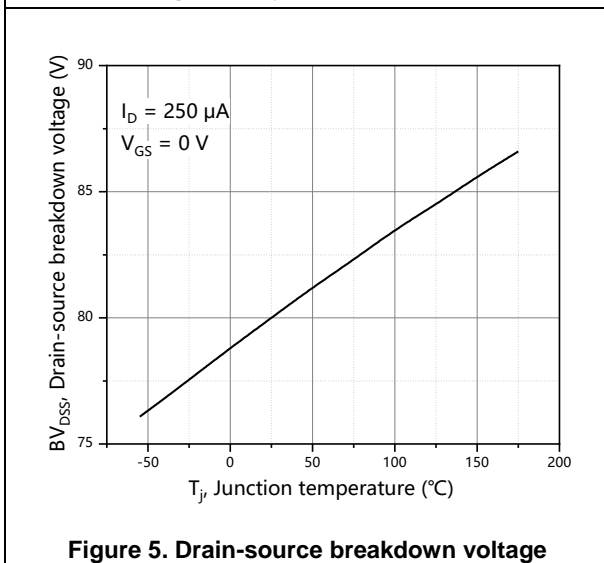

Figure 5. Drain-source breakdown voltage

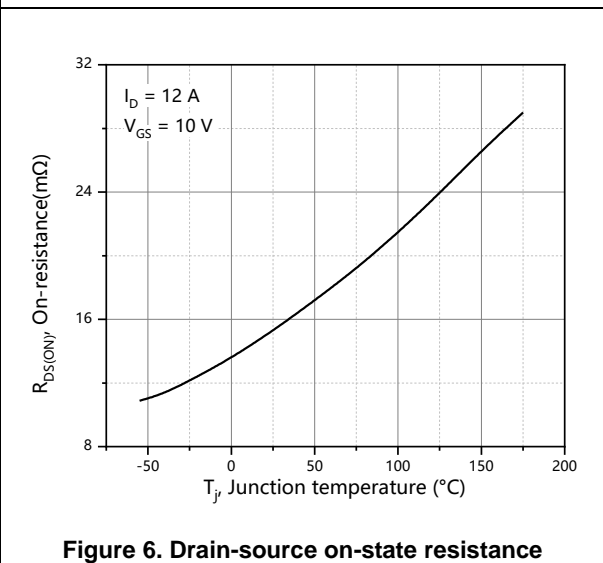

Figure 6. Drain-source on-state resistance

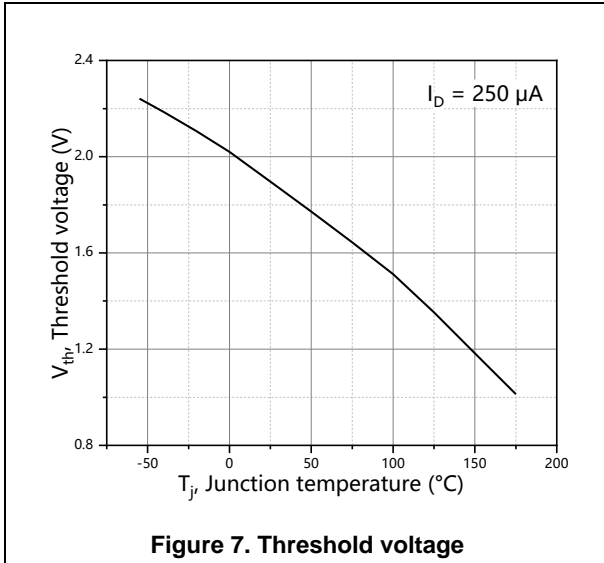

Figure 7. Threshold voltage

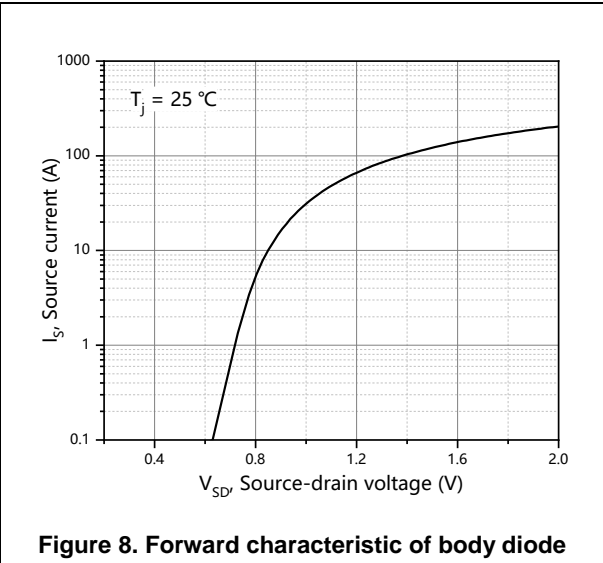

Figure 8. Forward characteristic of body diode

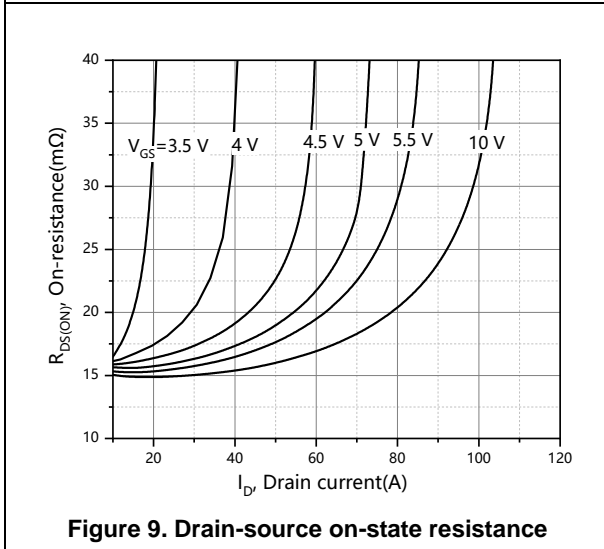

Figure 9. Drain-source on-state resistance

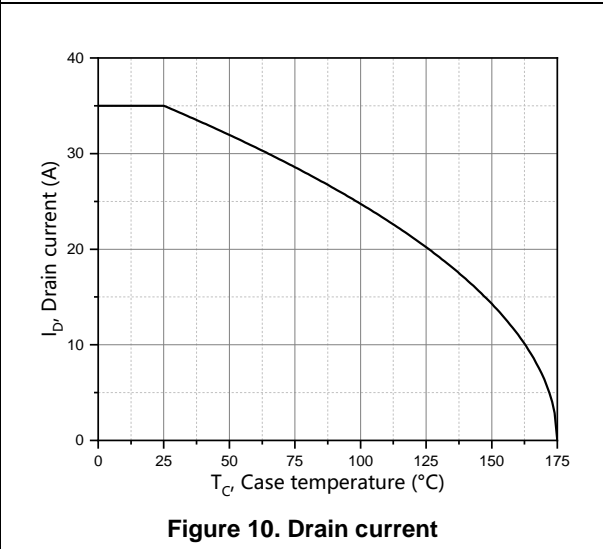

Figure 10. Drain current

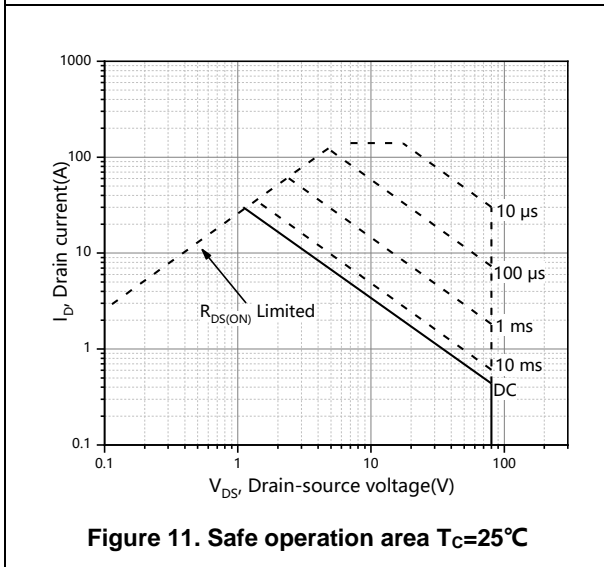

Figure 11. Safe operation area T_C=25°C

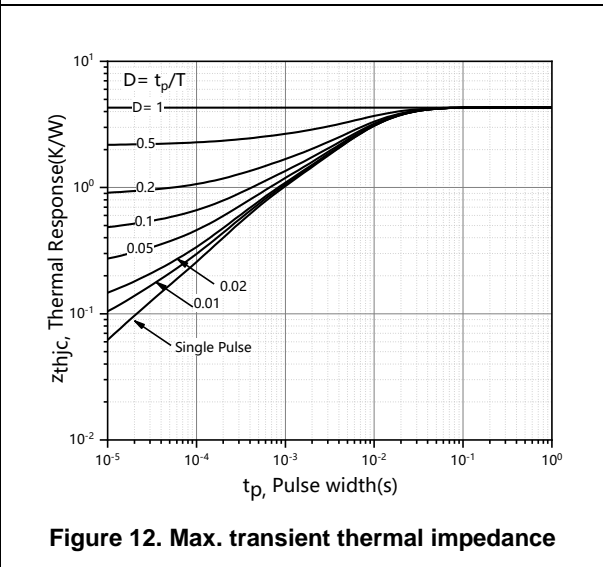

Figure 12. Max. transient thermal impedance

Test circuits and waveforms



Figure 1. Gate charge test circuit & waveform



Figure 2. Switching time test circuit & waveforms

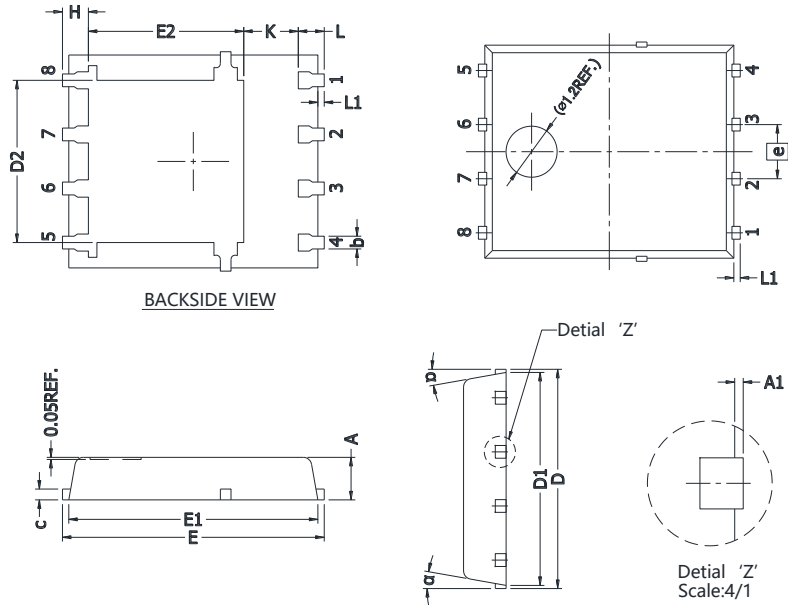

Figure 3. Unclamped inductive switching (UIS) test circuit & waveforms



Figure 4. Diode reverse recovery test circuit & waveforms

Package Information



| Symbol | mm | | |
|----------|----------|------|------|
| | Min | Nom | Max |
| A | 0.90 | 1.00 | 1.10 |
| A1 | 0.00 | - | 0.05 |
| b | 0.30 | 0.40 | 0.50 |
| c | 0.20 | 0.25 | 0.30 |
| D | 5.15 BSC | | |
| D1 | 5.00 BSC | | |
| D2 | 3.76 | 3.81 | 3.86 |
| E | 6.15 BSC | | |
| E1 | 5.80 | 5.85 | 5.90 |
| E2 | 3.45 | 3.65 | 3.85 |
| e | 1.27 BSC | | |
| H | 0.51 | 0.61 | 0.71 |
| K | 1.10 | - | - |
| L | 0.51 | 0.61 | 0.71 |
| L1 | 0.08 | 0.15 | 0.23 |
| α | 10° | 11° | 12° |

Version 1:PDFN5x6-J package outline dimension

Ordering Information

| Package Type | Units/ Reel | Reels/ Inner Box | Units/ Inner Box | Inner Boxes/ Carton Box | Units/ Carton Box |
|--------------|-------------|------------------|------------------|-------------------------|-------------------|
| PDFN5x6-J | 5000 | 1 | 5000 | 5 | 25000 |

Product Information

| Product | Package | Pb Free | RoHS | Halogen Free |
|------------|---------|---------|------|--------------|
| SFS08R20GF | PDFN5x6 | yes | yes | yes |

Legal Disclaimer

The information given in this document shall in no event be regarded as a guarantee of conditions or characteristics. With respect to any examples or hints given herein, any typical values stated herein and/or any information regarding the application of the device, Oriental Semiconductor hereby disclaims any and all warranties and liabilities of any kind, including without limitation, warranties of non-infringement of intellectual property rights of any third party.

For further information on technology, delivery terms and conditions and prices, please contact the Oriental Semiconductor sales representatives (www.orientalsemi.com).

© Oriental Semiconductor Co.,Ltd. All Rights Reserved /